

SIZE	A	ØB	C	D	E
1/4"	46.6	11.5	75	50	21.5
3/8"	46.6	12.5	75	50	21.5
1/2"	56.3	15.0	95	56.5	24
3/4"	61.5	20.0	95	60.5	31.5
1"	75.5	24	120	68.8	40
1 1/4"	85.8	31	120	75	49
1 1/2"	94.8	37	150	83.5	55
2"	114.2	50	150	95	67
2 1/2"	139.8	62	220	127.3	84
3"	156.4	75	220	136.1	98

NO.	PART NAME	MATERIAL	Q'TY
1	BODY	CF8M	1
2	CAP	CF8M	1
3	BALL	CF8M	1
4	BALL SEAT	PTFE	2
5	STEM	SS.316	1
6	GASKET	PTFE	1
7	THRUST WASHER	PTFE	1
8	STEM PACKING	PTFE	1
9	GLAND	SS.304	1
10	HANDLE	SS.304	1
11	HANDLE NUT	SS.304	1
12	SLEEVE	VINYL GRIP	1

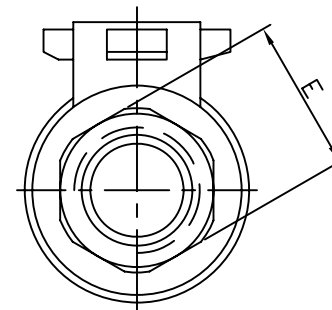

1/4"~1"

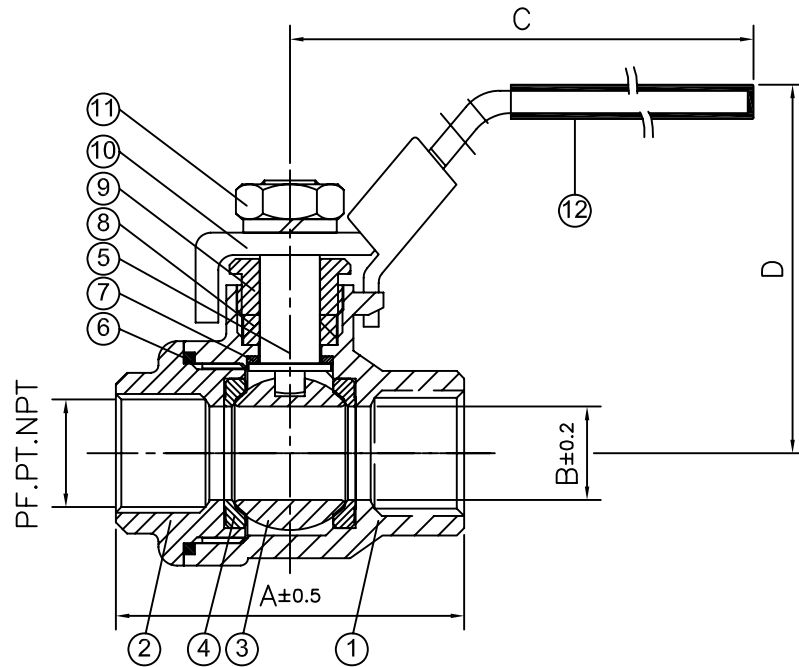
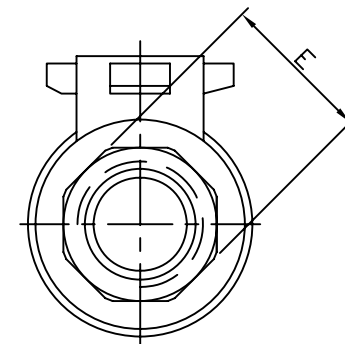

1 1/4"~3"

REV	DATE	DESCRIPTION	CODE	REVISER	REMARKS	MATERIAL	APPROVE	CHECK	SCALE	UNIT	TITLE	REV	A
					2-PC Ball Valve 1000 psi Full Port				FREE	mm		DRAWN BY	Kevin
									PART NO.	AF-20	⊕	DATE	2003.12.12
									DWG NO.	AF-20-C001		Q'TY	1
		2-PC 1/4"~3" ASSEMBLY DRAWING											2-PC BALL VALVE
									AF Anson Flow Corp.				